



PWM330

SWING GATE OPERATOR

for swing gates - 24V ——— EN



INDEX

A. SAFTY INSTRUCTION

3

B. PRODUCT DESCRIPTION AND INTENDED USE

3

B1. KIT CONTENT

3

B2. PRODUCT USAGE LIMITS

4

B3. DIMENSIONS

5

C. INSTALLATION

6

C1. INSTALLATION DIMENSIONS

6

C2. INSTALLATION OF GEARMOTORS

7

C3. MANUAL RELEASE OF MOTORS

8

C4. INSTALLATION OF THE CONTROL BOX

8

D. COMMISSIONING

9

D1. PC190U CONTROL BOARD

9

D2. MOTOR WIRING

10

D3. WIRING OF ACCESSORIES

11

D4. REMOTE LEARNING

12

D5. SAFETY DEVICE LOGIC

13

D6. PROGRAMMING

14

D7. PARAMETER TABLE

15-16

D8. SYSTEM LEARNING

17

D9. RESET TO DEFAULT SETTINGS

17

E. SMARTPHONE CONTROL WITH EYEOPEN MOBILE APPLICATION

18

E1. WB1 WIFI MODULE

18

E2. QUICK SET UP GUIDE

18-20

F. TECHNICAL SPECIFICATIONS

20

G. MAINTENANCE AND TROUBLESHOOTING

21

A. SAFTY INSTRUCTION

WARNING!

Please read this instruction manual carefully before the installation of gate-automated system.

This manual is exclusively for qualified installation personnel. Powertech Automation Inc. is not responsible for improper installation and failure to comply with local electrical and building regulations.

Keep all the components of the kit content and this manual for further consultation.

In this manual, please pay extra attention to the contents marked by the symbol: 

Be aware of the hazards that may exist in the procedures of installation and operation of the gate-automated system.

Besides, the installation must be carried out in conformity with local standards and regulations.

If the system is correctly installed and used following all the standards and regulations, it will ensure a high degree of safety.

Make sure that the gates work properly before installing the gate-automated system and confirm the gates are appropriate for the application.

Do not let children operate or play with the gate-automated system.

Do not cross the path of the gate-automated system when operating.

Please keep all the control devices and any other pulse generator away from children to avoid the gate-automated system being activated accidentally.

Do not make any modifications to any components except that it is mentioned in this manual.

Do not try to manually open or close the gates before you release the gear motor.

If there is a failure that cannot be solved and is not mentioned in this manual, please contact qualified installation personnel.

Do not use the gate-automated system before all the procedures and instructions have been carried out and thoroughly read.

Test the gate-automated system weekly and have qualified installation personnel to check and maintain the system at least every 6-month.

Install warning signs (if necessary) on the both sides of the gate to warn the people in the area of potential hazards.

B. PRODUCT DESCRIPTION AND INTENDED USE

B1. KIT CONTENT

► MOTORS ◀

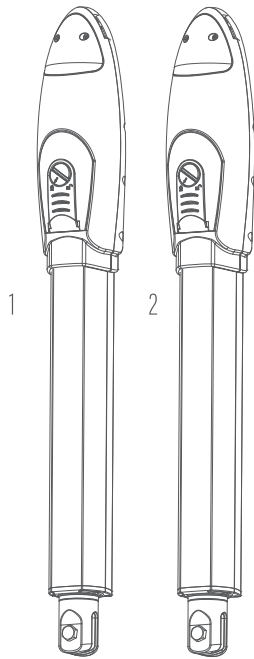

► FASTEN ◀

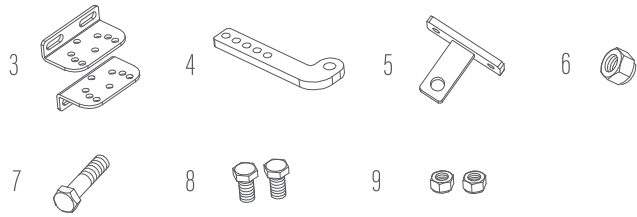

► ACCESSORIES ◀

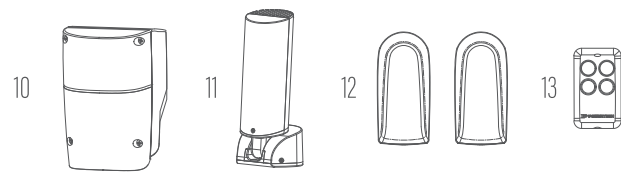

► REF.	DESCRIPTION	QUANTITY ◀
1.	Motor 1 (Master)	1
2.	Motor 2 (Slave)	1
3.	Bracket plate	4
4.	Front bracket	2
5.	Rear end Bracket	2
6.	M8*40L hex bolt	2
7.	M8 self-locking nut	2
8.	Washer	4
9.	Washer	4
10.	PC190U Control Box	1
11.	Flashing light	1
12.	Photocells	1
13.	Remote	2

B2. PRODUCT USAGE LIMITS

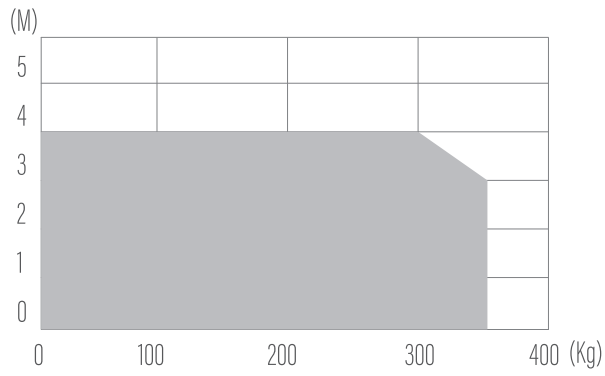

B3. DIMENSIONS

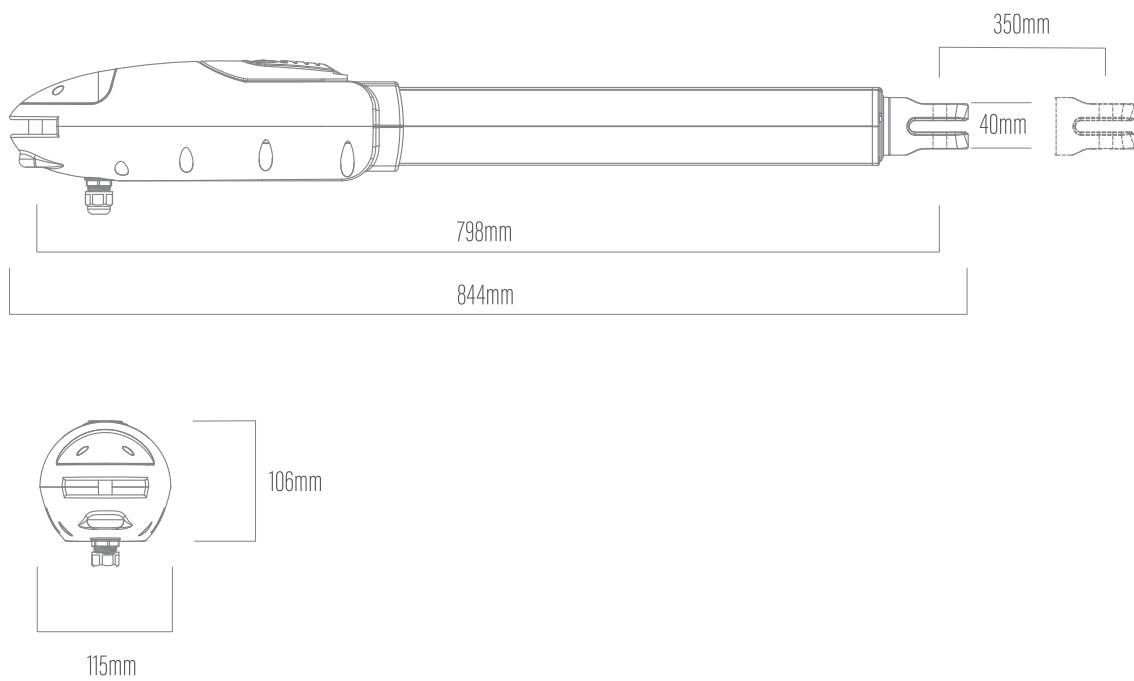

C. INSTALLATION

C1. INSTALLATION DIMENSIONS

● DIMENSIONS FRONT AND REAR BRACKET

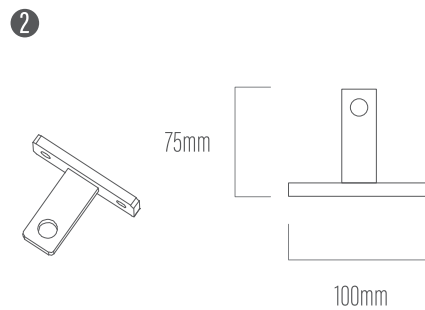
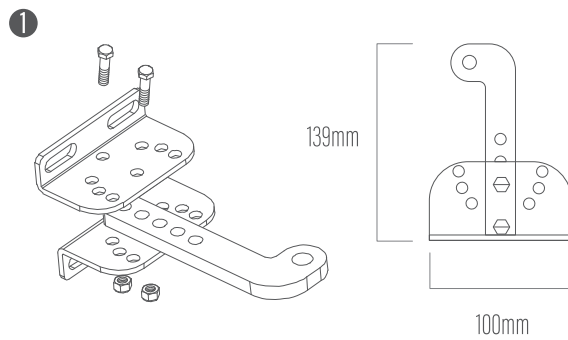
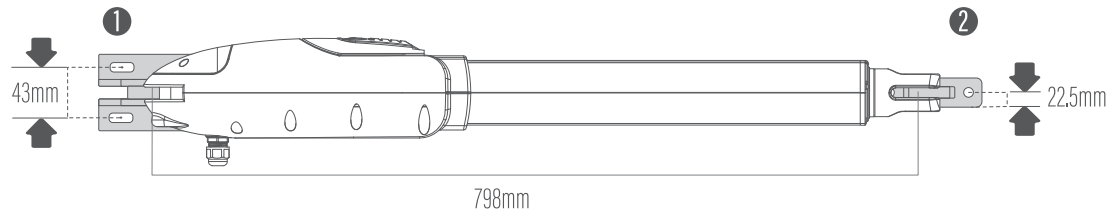

● FORWARD OPENING

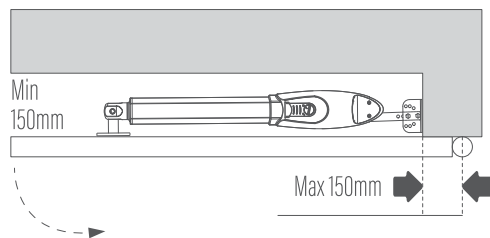

● OUTWARD OPENING

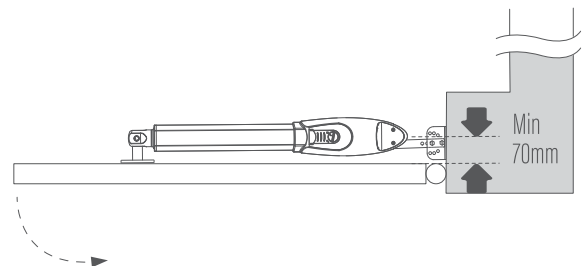

● INSTALLATION DIMENSIONS

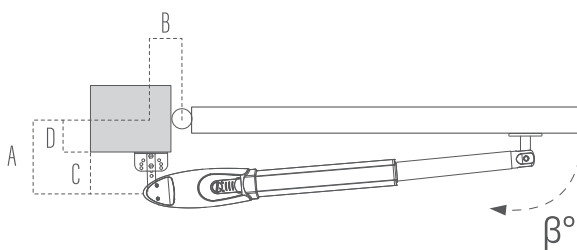

		PW330							
A \ B	B	120	130	140	150	160	170	180	190
120									
130									
140									
150									
160									
170									
180									
190									

$\beta > 120^\circ$
 $\beta = 110^\circ - 120^\circ$
 $\beta = 100^\circ - 110^\circ$
 $\beta = 90^\circ - 100^\circ$
 $\beta < 90^\circ$

C2. INSTALLATION OF GEARMOTORS

1. Choose the correct dimensions of the motors and position to be installed.
2. Check if the mounting surface the brackets to be installed is smooth, vertical and rigid.
3. Arrange the cable conduit for power supply cable of the motors.
4. Loosen the screw and remove the cover of the motor as shown in Figure 1.
5. Place the leaves in the closed position.
6. Refer to the distance of "B" in dimensions, place the rear plate in the correct position on the mounting surface. Inspect if the distance is proper as shown in dimensions (section B3) i.e. the position the front plate of the motor to be installed.
7. Place two post brackets on the surface to be installed and mark the drilling points, then drill minimum diameter of 8mm holes by four on the mounting surface to be installed and fasten up the brackets with screws and washers.
8. Please make sure the front plate is completely installed horizontally.
9. Refer to dimensions (section B3), the distance between front plate of the motor and rear plate is 875mm (PW330), the difference in height is 18.3mm (PW330).
10. Clamp and fix the motor front plate on the door temporarily.
11. Lift up the motor and insert the screws into the front plate.
12. Lift the motor overhead and push the gate to the end until the screw holes of the motor end matches the holes on the rear plate. Fasten the motor to the rear plate with the bolt as shown in Figure 4.
13. Fasten the nut tightly and loosen it for half round for motor supporting in rotating.
14. Fasten the motor front end to the front plate with the bolt and nut tightly. Fully tighten the screw.
15. Use appropriate release key to release the gear motor.
16. Try to push the released gate and make sure the motor can be manually moved easily.
17. Make sure the motor front plate can be fastened on the gate to be installed permanently.
18. Use the appropriate release key to fasten the gear motor again.

figure 1

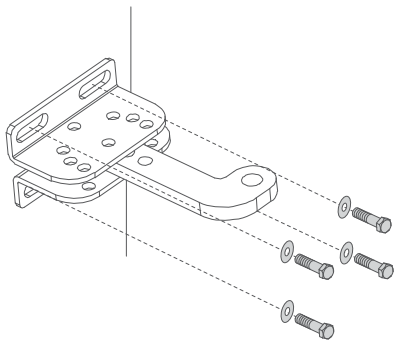

figure 2

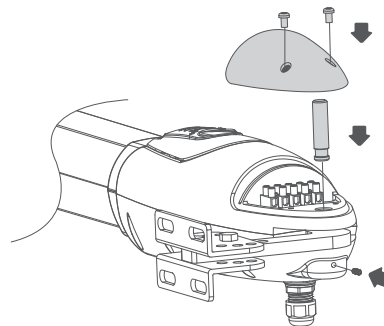

figure 3

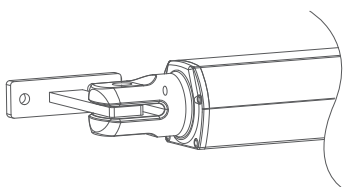
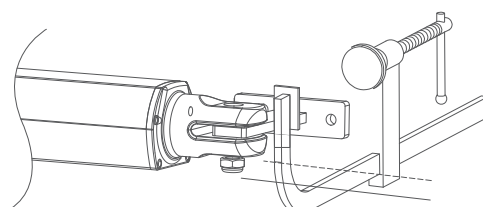

figure 4



C3. MANUAL RELEASE OF THE MOTOR

- To unlock the device

1. Insert the key
2. Turn it anti-clockwise by 180°
3. The gate leaf can now be moved manually to the desired position.

- To lock the device

1. Insert the key
2. Turn it clockwise by 180°
3. Remove the key

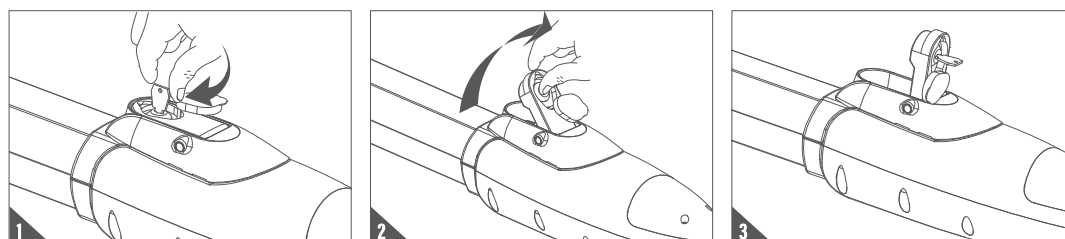

C4. INSTALLATION OF THE CONTROL BOX

1. Remove the cover by unscrewing the 4 screws from the control box.
2. Use a screwdriver to puncture the holes beneath the bottom of the control box.
3. Install the control box

figure 1

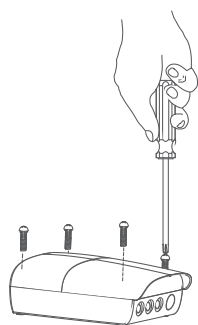

figure 2

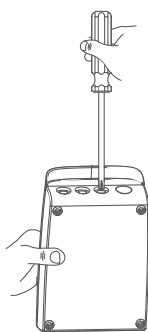
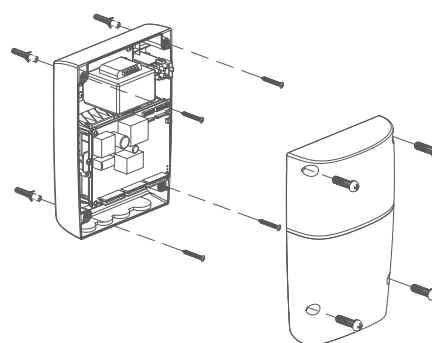
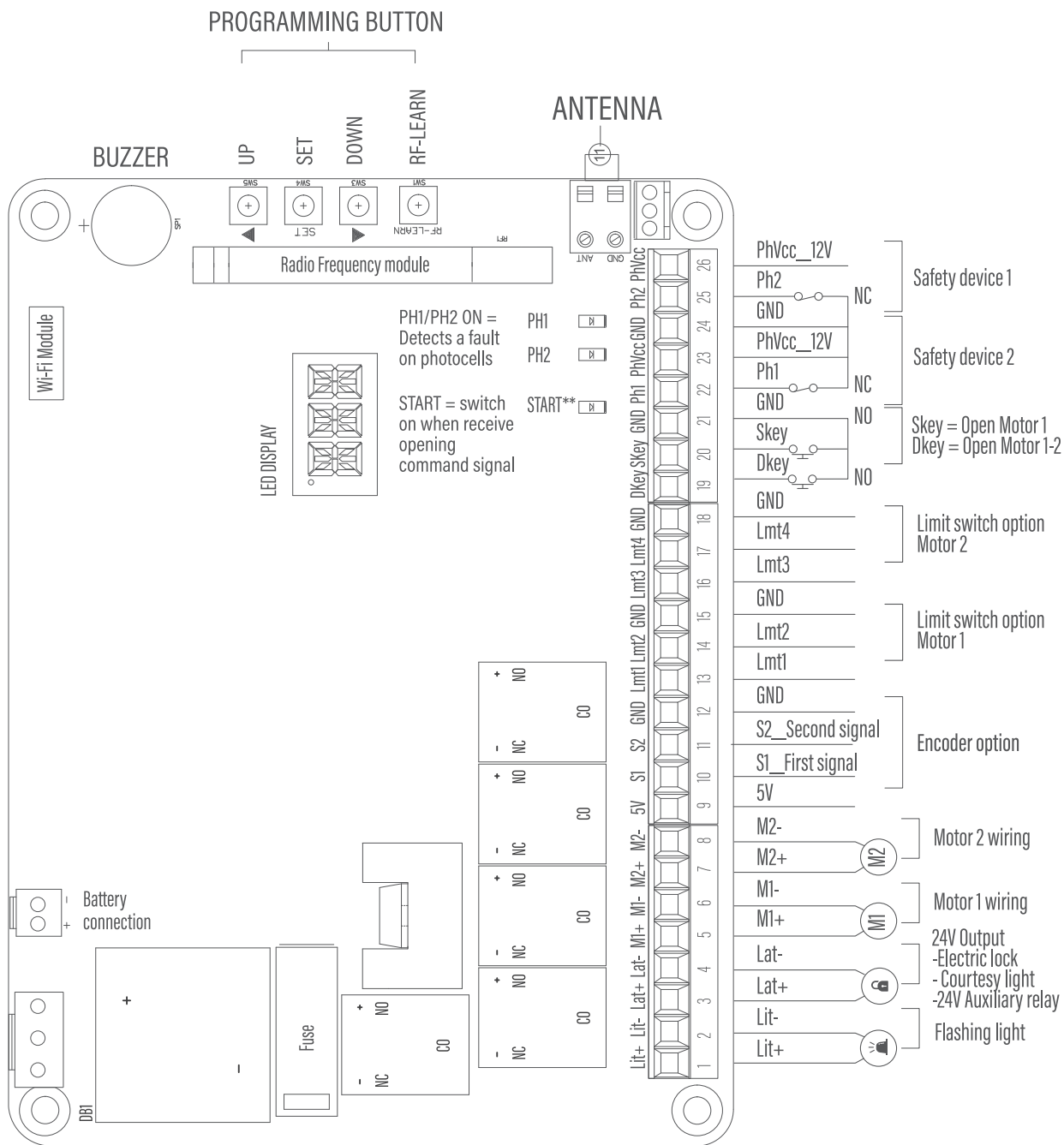

figure 3



D. COMMISSIONING

D1. PC190U CONTROL BOARD



MOTOR is the MASTER Motor that will open first and close last.

! WARNING ! BY DEFAULT, THE SAFETY DEVICES PH1-PH2 ARE DISABLED. (PARAMETER FD AND FE)
 When powering on for the first time, the LED display will show N-L = System learning not completed.
 DURING STANDARD OPERATION, the photocells are wired and aligned, the 3 LED indicators are OFF.
 Control : By passing your hand in front of the photocell beam, LED 1 will switch ON.

D2. MOTOR WIRING

- MOTOR WITHOUT LIMIT SWITCH

! MANDATORY : Make sure stoppers are placed on the ground or on the motors

- Refer to parameter table - PARAMETER **F 11** (DEFAULT SETTING)

- MOTOR 1 installed on the LEFT pillar

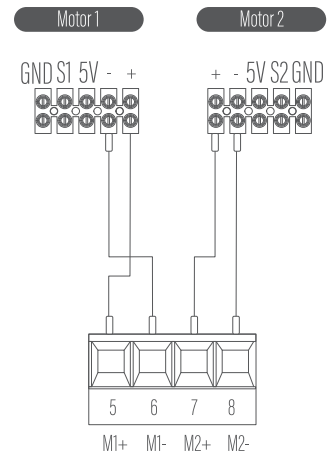
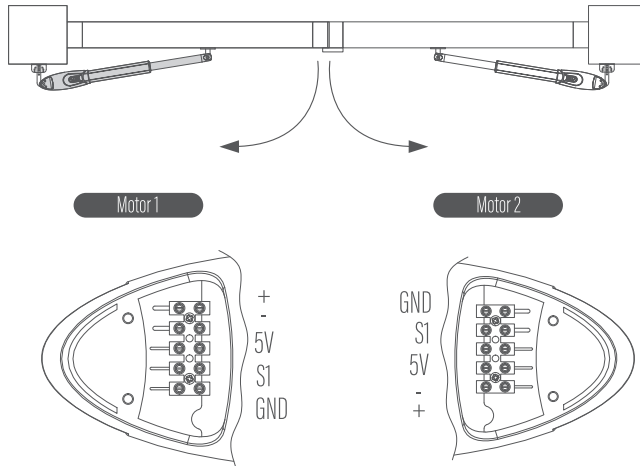

- MOTOR 1 installed on the RIGHT pillar

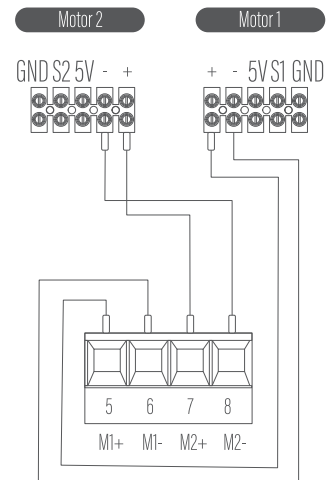
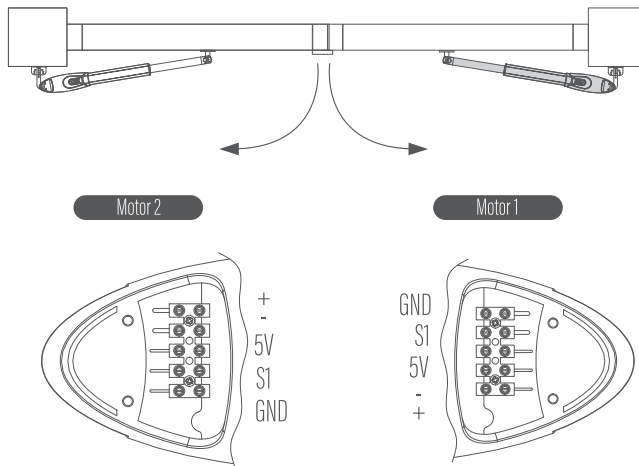

D3. WIRING OF ACCESSORIES

- Safety Device 1 wiring

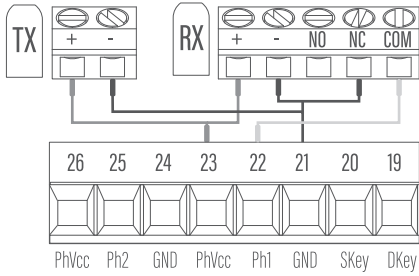

- Safety Device 2 wiring

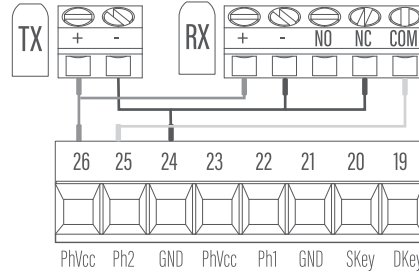

- Auxiliary Device wiring

Dkey : Complete open
Skey : Partial open

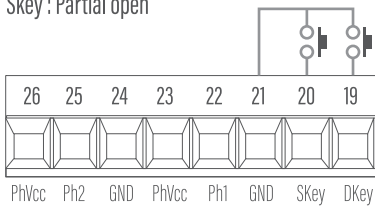

- 12V available to power accessories

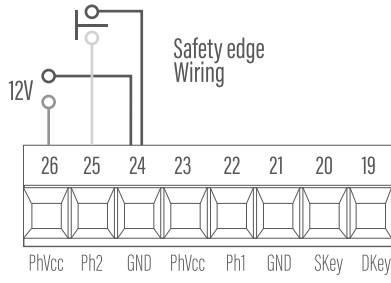

- Battery wiring (optional)

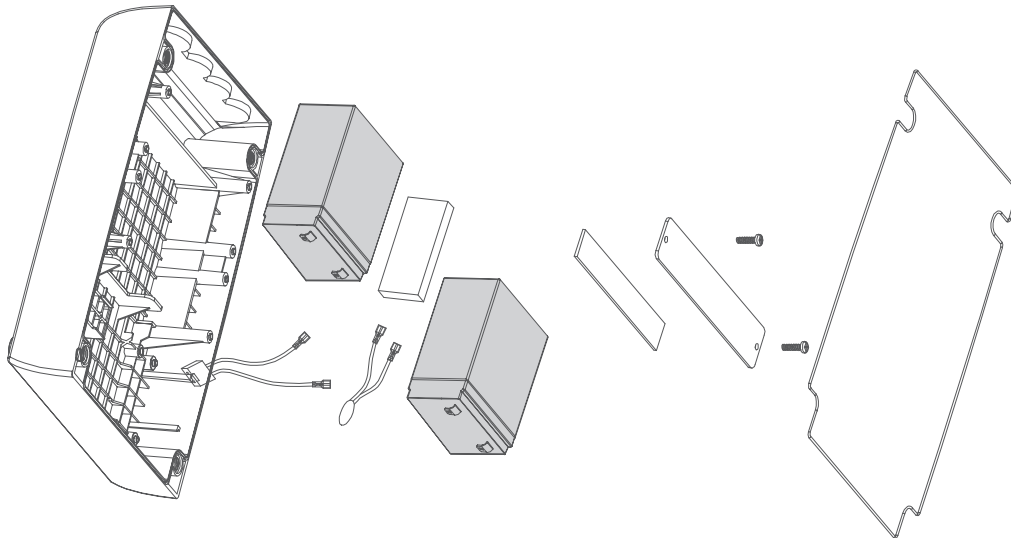

D4. REMOTE LEARNING

! **MANDATORY** : Before processing system learning, you must first memorize the remotes.

● RESET (DELETE) ALL THE REMOTES

Press and hold RF button. After 10 seconds, the LED display will first show **DKY** then **DAL** that confirms that all the transmitters have been deleted.

● OPEN/CLOSE/STOP ON DUAL GATE

Press RF Learn button. The LED display show **OSC**
Press and hold a button on the remote for at least 1 second then release. **OSC** blinks 3 times, completing the memorization process. You have 5 seconds to memorize another remote.

● OPEN/STOP/CLOSE ON SINGLE GATE (PEDESTRIAN OPENING)

Press RF Learn button. The LED display show **OSC**. Press RF button a 2nd time, the LED display show **PED**
Press and hold a button on the remote for at least 1 second then release. **PED** blinks 3 times, completing the memorization process. You have 5 seconds to memorize another remote.

● COMMAND FOR AUXILIARY DEVICE (FM FUNCTION)

Press RF Learn button. The LED display show **OSC**. Press RF button a 2nd time, the LED display show **PED**
Press RF button a 3rd time, the LED display show **LIT**.

Press and hold a button on the remote for at least 1 second then release. **LIT** blinks 3 times, completing the memorization process. You have 5 seconds to memorize another remote.

D5. SAFETY DEVICE LOGIC

● MOTOR REACTION FOLLOWING A FAULT ON CONTACT PH1 / PH2 – PARAMETER SETTINGS SELECTION - FA

! *IMPORTANT : PH1 and PH2 are disabled by default.*

FA-1 – Anticrush safety between the gate and the wall		
Safety device category	Photocells default on PH1	Safety edge default on PH2
Gate fully closed	No effect	No effect
Opening phase	No effect	Stop and close
Stop during cycle	Reload pause time => Automatic closing	No effect
Gate fully opened	Reload pause time => Automatic closing at slow speed	No effect
Closing phase	Stop => Open at slow speed	No effect
FA-2 -Security during closing stage		
Safety device category	Photocells default on PH1	Safety edge default on PH2
Gate fully closed	Blocks the open command	No effect
Opening phase	No effect	Stop => Reverse 2 seconds => Pause time => Automatic closing
Stop during cycle	Reload pause time => Automatic closing at slow speed	No effect
Gate fully opened	Reload pause time => Automatic closing	Reload pause time => Automatic closing
Closing phase	Stop => Open at slow speed	Stop => Reverse 2 seconds => Pause time => Automatic closing
FA-3 - Loop detector		
Safety device category	Photocells default on PH1	Loop detector default on PH2
Gate fully closed	No effect	Open
Opening phase	No effect	No effect
Stop during cycle	Reload pause time => Automatic closing	Open
Gate fully opened	Reload pause time => Automatic closing	Reload pause time => Automatic closing
Closing phase	Stop => Open at slow speed	Stop => Open at slow speed
FA-4 - Photocells on pillars and photocells on column		
Safety device category	Photocells default on PH1	Photocells default on PH2
Gate fully closed	No effect	No effect
Opening phase	No effect	No effect
Stop during cycle	Reload pause time => Automatic closing	Open
Gate fully opened	Stop => Reload pause time => Automatic closing	Reload pause time => Automatic closing
Closing phase	Open	Stop => Open at slow speed
FA-5 - Quick closing - Pausing time is reduced to 5 seconds		
Safety device category	Photocells default on PH1	Photocells default on PH2
Gate fully closed	No effect	No effect
Opening phase	Pause time before automatic closing reduced to 5 seconds	Pause time before automatic closing reduced to 5 seconds
Stop during cycle	Pause time before automatic closing reduced to 5 seconds	Pause time before automatic closing reduced to 5 seconds
Gate fully opened	Pause time before automatic closing reduced to 5 seconds	Pause time before automatic closing reduced to 5 seconds
Closing phase	Open => Reduce pause time to 5 seconds	Open => Reduce pause time to 5 seconds
FA-6 - Standard residential mode ***DEFAULT SETTING***		
Safety device category	Photocells default on PH1	Photocells default on PH2
Gate fully closed	No effect	No effect
Opening phase	No effect	No effect
Stop during cycle	Reload pause time => Automatic closing	Reload pause time => Automatic closing
Gate fully opened	Reload pause time => Automatic closing	Reload pause time => Automatic closing
Closing phase	Open	Open
FA-7 - Condominium mode. Transmitters only accept signal for opening / Automatic closing is mandatory		
Safety device category	Photocells default on PH1	Photocells default on PH2
Gate fully closed	No effect	No effect
Opening phase	No effect	No effect
Stop during cycle	Impossible	Impossible
Gate fully opened	No effect	No effect
Closing phase	Open	Open

D6. PROGRAMMING

● INDICATIONS ON THE LED DISPLAY

! *During the programming and operation, the LED display is ON and provides indications.*

N-L = System learning not completed
 LEA = In process of system learning
 S-G = Completed system learning for single gate
 D-G = Completed system learning for dual gate
 OPN = Motors in opening phase
 CLS = Motors in closing phase
 STP = Fault (display for 10 seconds)
 CLN = Return to default setting
 FI = Motor wiring fault

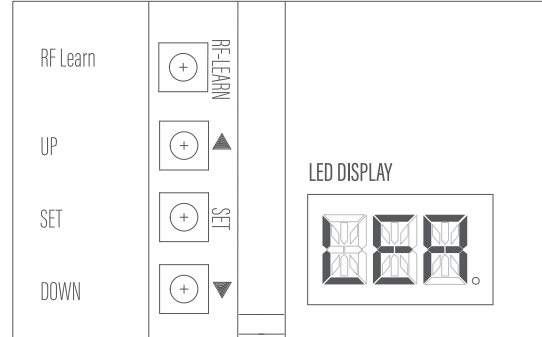

Indication example on the LED display

● PARAMETER SETTINGS

! *WARNING ! Depending on the placement of the control unit, the programming buttons may be located on the right or left side, the RF button at the top or bottom.*

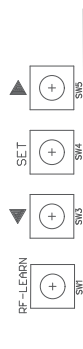

1. Press and hold ▲ / SET for 3 seconds
2. The LED display « F1 » parameter setting.
3. Select main setting with ▲ / ▼ then confirm with SET.
4. Display of the sub-setting (ex: parameter F1-subvalue=1)
5. Modify sub-setting value with ▲ / ▼ (ex: F1-1, F1-2···)
6. Validate sub-setting with SET.
7. Press ▲ / ▼ to display and configure other settings···

! *The LED display will switch off after 8 seconds if no button is pressed.*



D7. PARAMETER TABLE

SETTING	DESCRIPTION				DEFAULT SETTING
F1	MOTOR WITHOUT LIMIT SWITCH / WITH LIMIT SWITCH / WITH ENCODERS				F1-1
	F1-1 : Motor without limit switch, MANDATORY : Stoppers must be placed on the ground or on the motor F1-2 : Limit switch F1-3 : Encoders - Wiring on 5V/S1 and 5V/S2				
F2	MOTOR FORCE DURING OPENING PHASE				F2-2
	F2-1 = 1 amp F2-2 = 2 amp F2-3 = 3 amp F2-4 = 4 amp	F2-5 = 5 amp F2-6 = 6 amp F2-7 = 7 amp	Recommended value: PW200 = 2A / 4A PW320/330 = 2A / 5A PW530 = 2A / 6A	⚠ WARNING! Do not exceed recommended value or you may damage the motors	
F3	MOTOR FORCE DURING CLOSING PHASE				F3-2
	F3-1 = 1 amp F3-2 = 2 amp F3-3 = 3 amp F3-4 = 4 amp	F3-5 = 5 amp F3-6 = 6 amp F3-7 = 7 amp	Recommended value: PW200 = 2A / 4A PW320/330 = 2A / 5A PW530 = 2A / 6A	⚠ WARNING! Do not exceed recommended value or you may damage the motors	
F4	MOTOR SPEED DURING OPENING PHASE				F4-3
	F4-1 = 40% of full speed F4-3 = 75% of full speed F4-2 = 50% of full speed F4-4 = 100% of full speed				
F5	MOTOR SPEED DURING CLOSING PHASE				F5-3
	F5-1 = 40% of full speed F5-3 = 75% of full speed F5-2 = 50% of full speed F5-4 = 100% of full speed				
F6	MOTOR DECELERATION DURING OPENING AND CLOSING PHASE				F6-2
	F6-1 = 40% F6-3 = 75% F6-2 = 50% F6-4 = 100%				
F7	MOTOR DEPHASING DURING OPENING PHASE				F7-1
	F7-0 = 0 second F7-1 = 2 seconds F7-2 = 5 seconds	F7-3 = 10 seconds F7-4 = 15 seconds F7-5 = 20 seconds	F7-6 = 25 seconds F7-7 = 35 seconds F7-8 = 45 seconds	F7-9 = 55 seconds	
F8	MOTOR DEPHASING DURING CLOSING PHASE				F8-1
	F8-0 = 0 second F8-1 = 2 seconds F8-2 = 5 seconds	F8-3 = 10 seconds F8-4 = 15 seconds F8-5 = 20 seconds	F8-6 = 25 seconds F8-7 = 35 seconds F8-8 = 45 seconds	F8-9 = 55 seconds	
F9	PAUSE TIME BEFORE AUTOMATIC CLOSING				F9-0
	F9-0 : No automatic closing F9-1 = 3 seconds F9-2 = 10 seconds	F9-3 = 20 seconds F9-4 = 40 seconds F9-5 = 60 seconds	F9-6 = 120 seconds F9-7 = 180 seconds F9-8 = 300 seconds		

Temporary suspension of automatic closing function (Party mode)



It is possible to deactivate/reactivate the automatic closing function by pressing simultaneously on button A+B of the remote.

Automatic closing activated => Automatic closing deactivated = 4 Buzzer sounds

Automatic closing deactivated => Automatic closing activated = 2 Buzzer sounds

D7. PARAMETER TABLE

PARAMETERS	DESCRIPTION	DEFAULT SETTING
FA	SAFETY DEVICE LOGIC	FA-6
	FA-1 Anti-crush FA-4 Quick close 1 FA-6 Standard residential mode FA-2 Safety edge FA-5 Quick close 2 FA-7 Condominium mode FA-3 Loop detector	
FB	PEDESTRIAN OPENING (PARTIAL OPENING) ON MOTOR 1	FB-1
	FB-0 = Open motor 1 to the maximum range FB-1 = Open at 1/2 of the motor 1 maximum range	
FC	PRE-FLASHING (24V Flashing Light wiring on LIT+ / LIT- terminals)	FC-0
	FC-0 = Deactivated FC-1 = Activated = preflashes 3 seconds before the gate maneuver	
FD	SAFETY DEVICE 1	FD-0
	FD-0 = Deactivated FD-1 = Activated	
FE	SAFETY DEVICE 2	FE-0
	FE-0 = Deactivated FE-1 = Activated	
FF	BUZZER FUNCTION (Buzzer beeps during every gate maneuver)	FF-0
	FF-0 = Activated FF-1 = Deactivated (Can be useful during the commissioning and parameter settings)	
FG	ELECTRIC LOCK (wiring between LAT+ / LAT-)	FG-1
	FG-0 = Release OFF FG-1 = Release ON (During opening phase, motor reserves for 0,25s to release tension and unlock the electric lock)	
FH	LED DISPLAY DIRECTION (LED display direction is reversed on the articulated arm)	FH-1
	FH-0 = Value facing up FH-1 = Value facing down	
FI	SINGLE OR DUAL GATE	FI-2
	FI-1 = 1 motor (Wiring on M1+ / M1-) FI-2 = 2 motors	
FJ	MOTOR DISCHARGE AFTER CLOSING AND OPENING	FJ-2
	FJ-0 = No discharge FJ-2 = Retour de 0,2s FJ-5 = Reversal 0,5s FJ-1 = Reversal 0,1s FJ-4 = Retour de 0,4s FJ-6 = Reversal 0,6s	
FK	LAT+ / LAT- OUTPUT: ELECTRIC LOCK / ZONE LIGHTING / 24V OUTPUT (ACTIVATED BY BUTTON C ON THE REMOTE)	FK-1
	FK-1 = Power an electric lock in 24V (activated at start of the cycle) FK-2 = Zone lighting (activated during the movement of the gates) FK-3 = 24V output (courtesy light) controlled by the C button of the remote (adjustment of the duration with FL setting)	
FL	TRIGGER DURATION ON LAT+ / LAT- / 24V OUTPUT (ACTIVATED BY BUTTON C ON THE REMOTE)	FL-1
	FL-0 = ON / OFF FL-3 = 60 seconds FL-1 = 1 second FL-4 = 90 seconds FL-2 = 30 seconds FL-5 = 180 seconds	
FM	MOTOR SENSITIVITY (OVERCURRENT SENSITIVITY WHEN DETECTING AN OBSTACLE)	FM-1
	FM-1 = Stop after 0,2 second FM-2 = Stop after 0,5 second FM-3 = Stop after 0,75 second FM-4 = Stop after 1 second FM-5 = Stop after 1,5 second ⚠ WARNING ! For values exceeding 1 and 1,5 seconds, an additional safety device (safety edge) MUST be installed.	

D8. SYSTEM LEARNING



● PRE-CHECK UP BEFORE LEARNING PROCEDURE

- The motors, photocells and other safety devices are installed and wired.
- The stoppers or limit switches are installed and adjusted.
- The remotes are memorized.
- Unlock the motors. Manually move the gate to 75% of the travel and lock the motors.

● SYSTEM LEARNING PROCEDURE MANDATORY

1. Press and hold SET for 3 seconds
2. The LED display . Release the button to launch the system learning procedure.

 *The first movement of the motors must be in the closing direction.
If it is not the case, power off and invert the wiring of the 2 motors M+/M-*

3. The motor(s) perform(s) closing/opening movements then stop.
4. The display of  (2 motors) or  (1 motor) confirms that the learning procedure has been completed successfully.

 *During the learning phase, the LED display the motor power consumption (in Ampere). If this value fluctuates a lot during the gates movement, make sure to verify if there are any hard spots.*

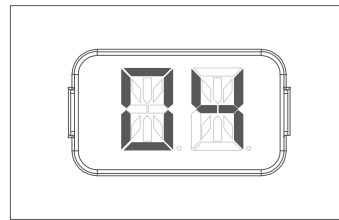



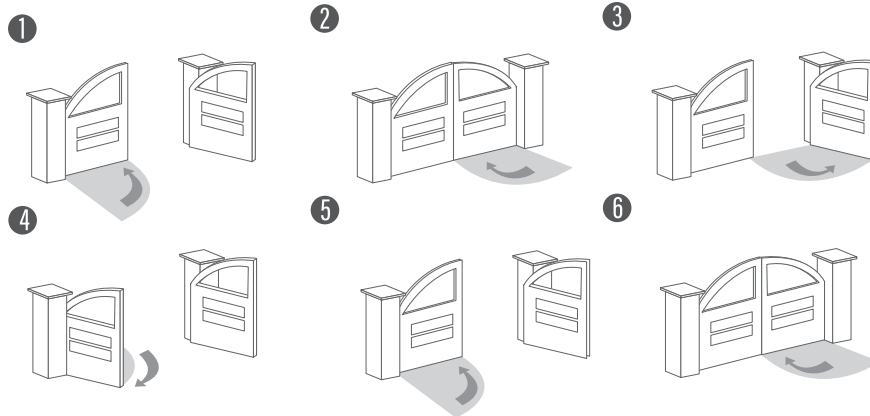

● DUAL GATE MOVEMENT DURING SYSTEM LEARNING PROCEDURE

1. Motor 2 close
2. Motor 1 close
3. Motor 1 open
4. Motor 2 open
5. Motor 2 close
6. Motor 1 close



D9. RESET TO DEFAULT SETTINGS

- Press and hold  SET / .
- The LED display  confirming that the system has successfully returned to default settings.
- Release the buttons => The LED display  (System learning not completed)

E. SMARTPHONE CONTROL WITH EYEOPEN MOBILE APPLICATION

E1.WB1 Wi-Fi MODULE

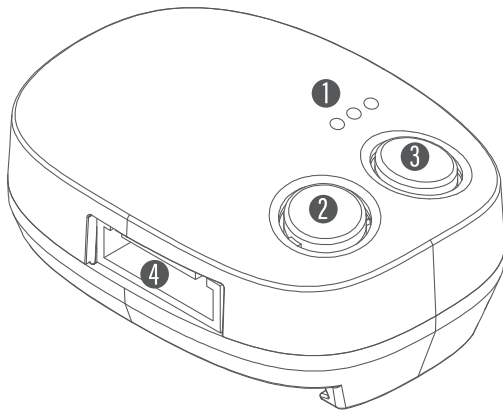

- ① LED INDICATORS
- ② R BUTTON (RESET)
- ③ P BUTTON (PAIR)
- ④ TERMINALS

● LED INDICATORS DESCRIPTION

BLUE: The blue LED blinks before pairing and stays ON when successfully connected to the WiFi.

GREEN : The green LED blinks once when the WB1 module receives a signal from the application.

If the WiFi is disconnected or the WiFi signal is weak, the green LED blinks constantly.

RED : Indicates that the system is disconnected or WiFi password is incorrect.

The range between WB1 module and router is 30 meters (in open space).

E2. QUICK SET UP GUIDE

- 💡 Select which smartphone will be the « owner » smartphone
The owner is able to give authorization to the other shared smartphones.
Activate and connect the smartphone to the WiFi that will be connected to the WB1 WiFi module.
EYEOPEN is only compatible with 2,4Ghz WiFi network

1. Download the EYEOPEN application on your smartphone .



2. Sign up and create login and password. Confirm and exit EYEOPEN application. Open your mailbox and activate the link received in the email.

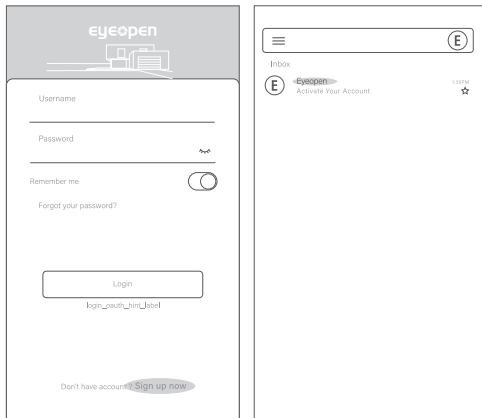

3. Open and login in the application.

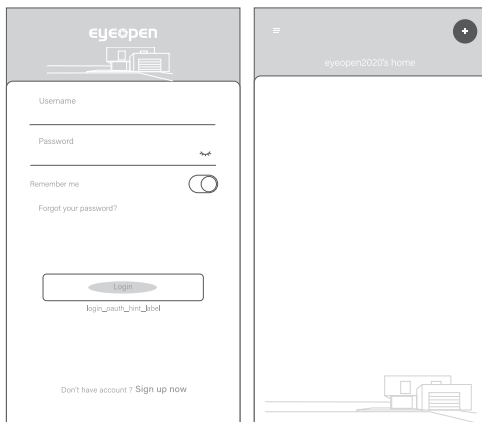

4. Tap the (+) icon to add device and follow the instructions. Key in and confirm the WiFi password and select the device.

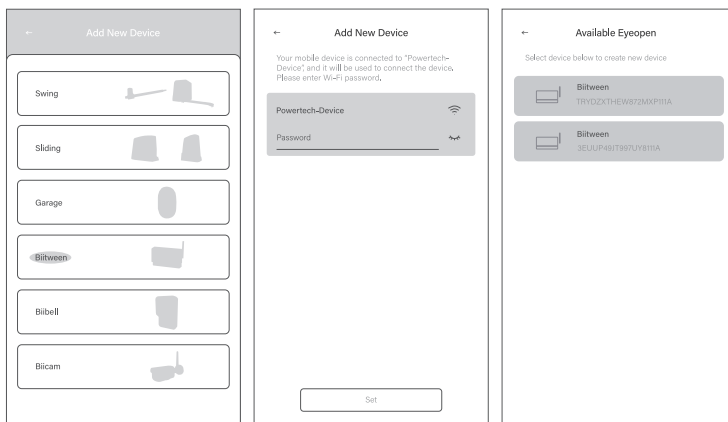

5. Set up the 6 digits PIN Code twice and confirm.

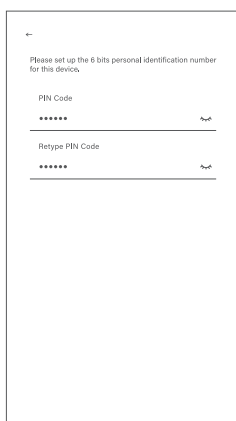

💡 By default, choose 123456 (Twice). You can later modify This PIN code once you are more comfortable with the application.

6. You have now access to the operation interface of the device. You can control, modify settings, add accessories or share the access.

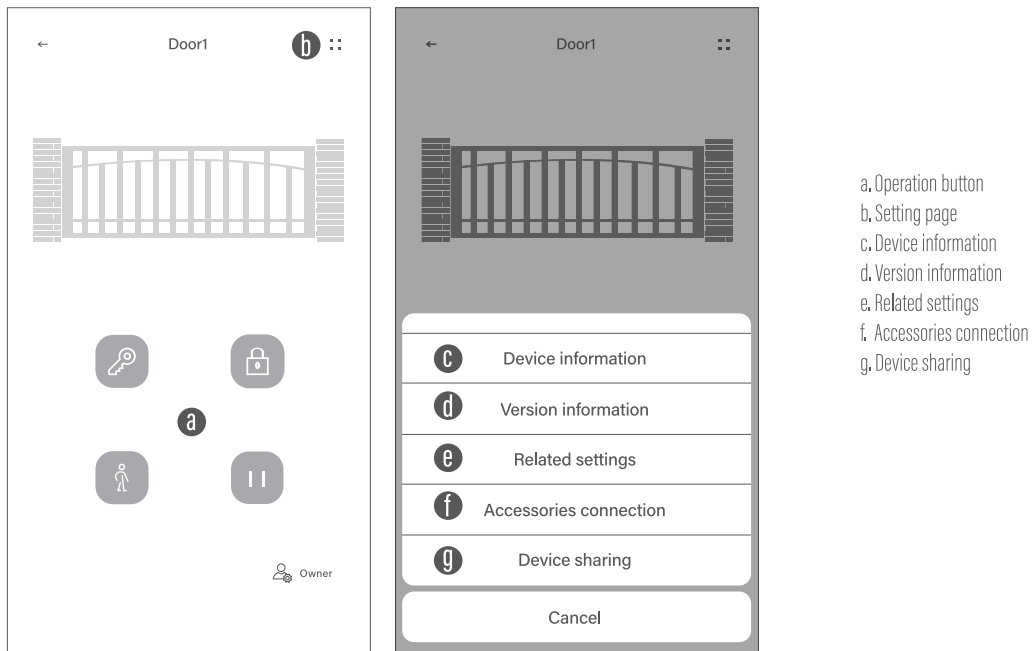

F. TECHNICAL SPECIFICATIONS

Model Name	PW330
Category	24V
Gear Type	Worm gear
Thrust	3000N
Stroke Length	350mm
Power Supply	24Vdc
Max Operating Current	5.5A pour 10 secondes
Max Gate Weight	350kg par vantail
Max Gate Length	4.0 meters
Duty Cycle	20%
Operating Temperatures	-20°C~+50°C
Dimension	844x115x106mm

G. MAINTENANCE AND TROUBLESHOOTING

MAINTENANCE

Conduct the following operations at least every 6 months. For intensive use scenarios, shorten this delay.

Disconnect the power supply

1. Clean and lubricate the screws, hinges with grease.
2. Make sure the fastening are properly tightened.
3. Make sure the wire connection is in good functioning conditions.

Connect the power supply

1. Double check the parameter settings.
2. Check the manual release.
3. Check the photocells and other safety devices.

TROUBLESHOOTING

Problem	Solution
The gate is not moving when pressing the buttons on the remote	<ol style="list-style-type: none"> 1. Check if LED2 blinks when pressing buttons on the remote 2. Check if the voltage on the batteries is above 22V 3. Check if LED3-4 are "ON". 4. Make sure all the wires are connected to the PCB terminals 5. Make sure the fuse is fully functional on the panel and power socket.
Transmission range on the remote/keypad is too short	<ol style="list-style-type: none"> 1. Make sure the antenna is well attached and screwed on the control board 2. Make sure there is no obstruction of the antenna (power or motor cables)
Flashing light does not function	<ol style="list-style-type: none"> 1. Make sure the wiring is correct
The gate stops during movement.	<ol style="list-style-type: none"> 1. Manually move the gate and check if there are any hard spots.
The gate does not move or only move towards a single direction.	<ol style="list-style-type: none"> 1. Verify the motors wiring. 2. Check the fuse status 3. Make sure there are no obstacles obstructing the photocells beam.
One gate fully closes but the other gate stops.	<p>Manually move the gate and check if there are any hard spots.</p> <ol style="list-style-type: none"> 1. Verify the motors wiring. 2. Check the fuse status 3. Make sure there are no obstacles obstructing the photocells beam. 4. Increase the F2-F3 settings (Force)

